

(12) INTERNATIONAL APPLICATION PUBLISHED UNDER THE PATENT COOPERATION TREATY (PCT)

(19) World Intellectual Property
Organization
International Bureau



(43) International Publication Date
11 December 2003 (11.12.2003)

PCT

(10) International Publication Number
WO 2003/102365 A1

- (51) International Patent Classification⁷: E21B 43/10 (74) Agents: MATTINGLY, Todd et al.; Haynes and Boone, LLP, 1000 Louisiana Street, Suite 4300, Houston, TX 77002-5012 (US).
- (21) International Application Number: PCT/US2003/011765
- (22) International Filing Date: 17 April 2003 (17.04.2003) (81) Designated States (*national*): AE, AG, AL, AM, AT, AU, AZ, BA, BB, BG, BR, BY, BZ, CA, CH, CN, CO, CR, CU, CZ, DE, DK, DM, DZ, EC, EE, ES, FI, GB, GD, GE, GH, GM, HR, HU, ID, IL, IN, IS, JP, KE, KG, KP, KR, KZ, LC, LK, LR, LS, LT, LU, LV, MA, MD, MG, MK, MN, MW, MX, MZ, NO, NZ, PL, PT, RO, RU, SD, SE, SG, SK, SL, TJ, TM, TR, TT, TZ, UA, UG, US, UZ, VN, YU, ZA, ZW.
- (25) Filing Language: English
- (26) Publication Language: English
- (30) Priority Data: 60/383,917 29 May 2002 (29.05.2002) US (84) Designated States (*regional*): ARIPO patent (GH, GM, KE, LS, MW, MZ, SD, SI, SZ, TZ, UG, ZM, ZW), Eurasian patent (AM, AZ, BY, KG, KZ, MD, RU, TJ, TM), European patent (AT, BE, BG, CH, CY, CZ, DE, DK, EE, ES, FI, FR, GB, GR, HU, IE, IT, LU, MC, NL, PT, RO, SE, SI, SK, TR), OAPI patent (BF, BJ, CF, CG, CI, CM, GA, GN, GQ, GW, ML, MR, NE, SN, TD, TG).
- (71) Applicant (*for all designated States except US*): EVENTURE GLOBAL TECHNOLOGY [US/US]; 16200 A Park Row, Houston, TX 77084 (US).
- (72) Inventor; and
- (75) Inventor/Applicant (*for US only*): RING, Lev [US/US]; 14220 Heatherhill Place, Houston, TX 77077 (US).

[Continued on next page]

(54) Title: SYSTEM FOR RADially EXPANDING A TUBULAR MEMBER

WO 2003/102365 A1

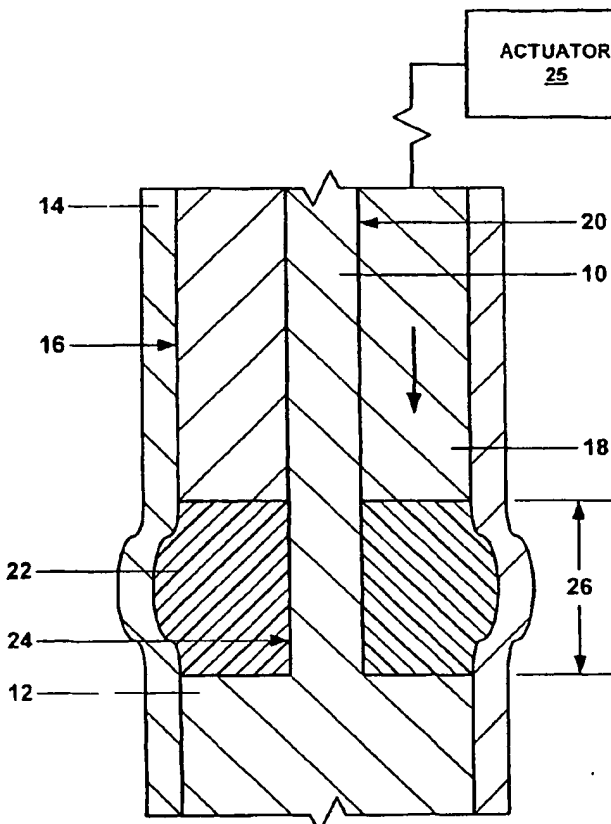

(57) Abstract: A system for radially expanding a tubular member (14).



Declaration under Rule 4.17:

— of inventorship (Rule 4.17(iv)) for US only

Published:

- with international search report
- with amended claims

Date of publication of the amended claims: 18 March 2004

For two-letter codes and other abbreviations, refer to the "Guidance Notes on Codes and Abbreviations" appearing at the beginning of each regular issue of the PCT Gazette.

AMENDED CLAIMS

[received by the International Bureau on 12 January 2004 (12.01.04);
original claims 1, 20, 39 amended; claims 46-93 added; remaining claims unchanged]

1. A method of radially expanding and plastically deforming at least a portion of an expandable tubular member, comprising:
 - positioning a resilient member within the interior of the expandable tubular member;
 - compressing the resilient member within the interior of the expandable tubular member to radially expand and plastically deform a portion of the expandable tubular member;
 - and
 - positioning an adjustable expansion device within the radially expanded and plastically deformed portion of the expandable tubular member;
 - expanding the adjustable expansion device within the radially expanded and plastically deformed portion of the expandable tubular member; and
 - displacing the adjustable expansion device relative to the expandable tubular member in the longitudinal direction to radially expand and plastically deform another portion of the expandable tubular member.

2. The method of claim 1, wherein the inside diameter of the radially expanded portion of the expandable tubular member is increased by up to about 22 percent during the radial expansion and plastic deformation.

3. The method of claim 1, further comprising:
 - positioning an adjustable expansion cone within the radially expanded and plastically deformed portion of the expandable tubular member;
 - expanding the adjustable expansion cone within the radially expanded and plastically deformed portion of the expandable tubular member; and
 - displacing the adjustable expansion cone relative to the expandable tubular member in the longitudinal direction to radially expand and plastically deform another portion of the expandable tubular member.

4. The method of claim 1, further comprising:
 - decompressing the resilient member within the interior of the expandable tubular member;
 - positioning the resilient member to another location within the interior of the expandable tubular member; and
 - compressing the resilient member within the interior of the expandable tubular member to radially expand and plastically deform another portion of the expandable tubular member.

5. The method of claim 1, further comprising:
positioning the expandable tubular member within a preexisting structure.
6. The method of claim 5, wherein the preexisting structure comprises a wellbore.
7. The method of claim 5, wherein the preexisting structure comprises a wellbore casing.
8. The method of claim 5, wherein the preexisting structure comprises a pipeline.
9. The method of claim 5, wherein the preexisting structure comprises a structural support.
10. The method of claim 5, further comprising:
compressing the resilient member within the interior of the expandable tubular member to
radially expand and plastically deform a portion of the expandable tubular member
into contact with the interior surface of the preexisting structure.
11. The method of claim 10, further comprising:
decompressing the resilient member within the interior of the expandable tubular member;
positioning the resilient member to another location within the interior of the expandable
tubular member; and
compressing the resilient member within the interior of the expandable tubular member to
radially expand and plastically deform another portion of the expandable tubular
member into contact with the interior surface of the preexisting structure.
12. The method of claim 11, wherein an intermediate portion of the expandable tubular member
positioned between the radially expanded and plastically deformed portions defines one or more radial
openings for conveying fluidic materials between the interiors of the expandable tubular member and
the preexisting structure.
13. The method of claim 12, wherein the preexisting structure comprises a wellbore that traverses
a subterranean formation.
14. The method of claim 13, wherein the subterranean formation comprises a source of
geothermal energy.
15. The method of claim 13, wherein the subterranean formation comprises a source of
hydrocarbons.

16. The method of claim 1, further comprising:
compressing the resilient member in the longitudinal direction within the interior of the expandable tubular member to radially expand and plastically deform a portion of the expandable tubular member.
17. The method of claim 1, wherein the resilient member comprises a resilient tubular member.
18. The method of claim 1, wherein the expandable tubular member comprises a solid expandable tubular member.
19. The method of claim 1, wherein the expandable tubular member defines one or more radial openings for conveying fluidic materials.
20. A system for radially expanding and plastically deforming at least a portion of an expandable tubular member, comprising:
means for positioning a resilient member within the interior of the expandable tubular member;
means for compressing the resilient member within the interior of the expandable tubular member to radially expand and plastically deform a portion of the expandable tubular member; and
means for positioning an adjustable expansion device within the radially expanded and plastically deformed portion of the expandable tubular member;
means for expanding the adjustable expansion device within the radially expanded and plastically deformed portion of the expandable tubular member; and
means for displacing the adjustable expansion device relative to the expandable tubular member in the longitudinal direction to radially expand and plastically deform another portion of the expandable tubular member.
21. The system of claim 20, wherein the inside diameter of the radially expanded portion of the expandable tubular member is increased by up to about 22 percent during the radial expansion and plastic deformation.
22. The system of claim 20, further comprising:
means for positioning an adjustable expansion cone within the radially expanded and plastically deformed portion of the expandable tubular member;
means for expanding the adjustable expansion cone within the radially expanded and plastically deformed portion of the expandable tubular member; and

means for displacing the adjustable expansion cone relative to the expandable tubular member in the longitudinal direction to radially expand and plastically deform another portion of the expandable tubular member.

23. The system of claim 20, further comprising:
means for decompressing the resilient member within the interior of the expandable tubular member;
means for positioning the resilient member to another location within the interior of the expandable tubular member; and
means for compressing the resilient member within the interior of the expandable tubular member to radially expand and plastically deform another portion of the expandable tubular member.
24. The system of claim 20, further comprising:
means for positioning the expandable tubular member within a preexisting structure.
25. The system of claim 24, wherein the preexisting structure comprises a wellbore.
26. The system of claim 24, wherein the preexisting structure comprises a wellbore casing.
27. The system of claim 24, wherein the preexisting structure comprises a pipeline.
28. The system of claim 24, wherein the preexisting structure comprises a structural support.
29. The system of claim 24, further comprising:
means for compressing the resilient member within the interior of the expandable tubular member to radially expand and plastically deform a portion of the expandable tubular member into contact with the interior surface of the preexisting structure.
30. The system of claim 29, further comprising:
means for decompressing the resilient member within the interior of the expandable tubular member;
means for positioning the resilient member to another location within the interior of the expandable tubular member; and
means for compressing the resilient member within the interior of the expandable tubular member to radially expand and plastically deform another portion of the expandable tubular member into contact with the interior surface of the preexisting structure.

31. The system of claim 30, wherein an intermediate portion of the expandable tubular member positioned between the radially expanded and plastically deformed portions defines one or more radial openings for conveying fluidic materials between the interiors of the expandable tubular member and the preexisting structure.
32. The system of claim 31, wherein the preexisting structure comprises a wellbore that traverses a subterranean formation.
33. The system of claim 32, wherein the subterranean formation comprises a source of geothermal energy.
34. The system of claim 32, wherein the subterranean formation comprises a source of hydrocarbons.
35. The system of claim 20, further comprising:
means for compressing the resilient member in the longitudinal direction within the interior of the expandable tubular member to radially expand and plastically deform a portion of the expandable tubular member.
36. The system of claim 20, wherein the resilient member comprises a resilient tubular member.
37. The system of claim 20, wherein the expandable tubular member comprises a solid expandable tubular member.
38. The system of claim 20, wherein the expandable tubular member defines one or more radial openings for conveying fluidic materials.
39. An apparatus for radially expanding and plastically deforming an expandable tubular member, comprising:
a support member;
a resilient member coupled to the support member;
an actuator operably coupled to the resilient member for controllably compressing the resilient member to thereby radially expand and plastically deform the expandable tubular member; and
an adjustable expansion device coupled to the support member.

40. The apparatus of claim 39, wherein the resilient member comprises a tubular resilient member.
41. The apparatus of claim 39, further comprising an adjustable expansion cone coupled to the support member.
42. The apparatus of claim 39, wherein the actuator is adapted to compress the resilient member in the longitudinal direction and thereby cause the resilient member to expand in the radial direction.
43. The apparatus of claim 39, wherein the support member is fabricated from a rigid material.
44. The apparatus of claim 43, wherein the rigid material is selected from the group consisting of steel and aluminum.
45. The apparatus of claim 39, wherein the resilient member is fabricated from materials selected from the group consisting of natural rubber, synthetic rubber, and elastomeric material.
46. A method of radially expanding and plastically deforming at least a portion of an expandable tubular member, comprising:
positioning a resilient member within the interior of the expandable tubular member;
compressing the resilient member within the interior of the expandable tubular member to radially expand and plastically deform a portion of the expandable tubular member;
positioning an expansion device within the radially expanded and plastically deformed portion of the expandable tubular member; and
operating the expansion device to radially expand and plastically deform another portion of the expandable tubular member.
47. The method of claim 46, wherein the expansion device comprises an adjustable expansion device.
48. The method of claim 46, wherein the expansion device comprises a rotary expansion device.
49. The method of claim 46, wherein the expansion device comprises a pressurization device.
50. A system for radially expanding and plastically deforming at least a portion of an expandable tubular member, comprising:
means for positioning a resilient member within the interior of the expandable tubular member;

means for compressing the resilient member within the interior of the expandable tubular member to radially expand and plastically deform a portion of the expandable tubular member;

means for positioning an expansion device within the radially expanded and plastically deformed portion of the expandable tubular member; and

means for operating the expansion device to radially expand and plastically deform another portion of the expandable tubular member.

51. The system of claim 50, wherein the expansion device comprises an adjustable expansion device.

52. The system of claim 50, wherein the expansion device comprises a rotary expansion device.

53. The system of claim 50, wherein the expansion device comprises a pressurization device.

54. An apparatus for radially expanding and plastically deforming an expandable tubular member, comprising:

a support member;

a resilient member coupled to the support member;

an actuator operably coupled to the resilient member for controllably compressing the resilient member to thereby radially expand and plastically deform the expandable tubular member; and

an expansion device coupled to the support member.

55. The apparatus of claim 54, wherein the expansion device comprises an adjustable expansion device.

56. The apparatus of claim 54, wherein the expansion device comprises a rotary expansion device.

57. The apparatus of claim 54, wherein the expansion device comprises a pressurization device.

58. A method of recovering materials from a subterranean zone, comprising:

positioning an expandable tubular member that defines one or more radial passages within a wellbore that traverses the subterranean zone;

positioning a resilient member within the interior of the expandable tubular member;

compressing the resilient member within the interior of the expandable tubular member to radially expand and plastically deform a first portion of the expandable tubular member;

decompressing the resilient member within the interior of the expandable tubular member;
positioning the resilient member to another location within the interior of the expandable tubular member;
compressing the resilient member within the interior of the expandable tubular member to radially expand and plastically deform a second portion of the expandable tubular member; and
recovering materials from the subterranean zone through one or more of the radial passages of the expandable tubular member;
wherein the first and second portions of the expandable tubular member are spaced apart from one another.

59. The method of claim 58, wherein the radial passages of the expandable tubular member are defined between the first and second portions of the expandable tubular member.

60. The method of claim 58, wherein the materials comprise hydrocarbons.

61. The method of claim 58, wherein the materials comprise geothermal energy.

62. The method of claim 58, wherein an annulus defined between the portion of the expandable tubular member between the first and second portions of the expandable tubular member and the wellbore is fluidically isolated from another annulus defined between the expandable tubular member and the wellbore.

63. A system for recovering materials from a subterranean zone, comprising:

means for positioning an expandable tubular member that defines one or more radial passages within a wellbore that traverses the subterranean zone;

means for positioning a resilient member within the interior of the expandable tubular member;

means for compressing the resilient member within the interior of the expandable tubular member to radially expand and plastically deform a first portion of the expandable tubular member;

means for decompressing the resilient member within the interior of the expandable tubular member;

means for positioning the resilient member to another location within the interior of the expandable tubular member;

means for compressing the resilient member within the interior of the expandable tubular member to radially expand and plastically deform a second portion of the expandable tubular member; and

means for recovering materials from the subterranean zone through one or more of the radial passages of the expandable tubular member;

wherein the first and second portions of the expandable tubular member are spaced apart from one another.

64. The system of claim 63, wherein the radial passages of the expandable tubular member are positioned between the first and second portions of the expandable tubular member.

65. The system of claim 63, wherein the materials comprise hydrocarbons.

66. The system of claim 63, wherein the materials comprise geothermal energy.

67. A method of radially expanding and plastically deforming at least a portion of an expandable tubular member, comprising:

positioning a resilient member within the interior of the expandable tubular member;
compressing the resilient member within the interior of the expandable tubular member to radially expand and plastically deform a portion of the expandable tubular member;
positioning an expansion device within the expandable tubular member; and
operating the expansion device to radially expand and plastically deform the expandable tubular member.

68. The method of claim 67, wherein the expansion device comprises an adjustable expansion device.

69. The method of claim 67, wherein the expansion device comprises a rotary expansion device.

70. The method of claim 67, wherein the expansion device comprises a pressurization device.

71. A system for radially expanding and plastically deforming at least a portion of an expandable tubular member, comprising:

means for positioning a resilient member within the interior of the expandable tubular member;
means for compressing the resilient member within the interior of the expandable tubular member to radially expand and plastically deform a portion of the expandable tubular member;

means for positioning an expansion device within the expandable tubular member; and
means for operating the expansion device to radially expand and plastically deform the
expandable tubular member.

72. The system of claim 71, wherein the expansion device comprises an adjustable expansion device.
73. The system of claim 71, wherein the expansion device comprises a rotary expansion device.
74. A method of radially expanding and plastically deforming an expandable tubular member, comprising:
positioning a resilient member within the interior of the expandable tubular member;
compressing the resilient member within the interior of the expandable tubular member to
radially expand and plastically deform a portion of the expandable tubular member;
positioning an expansion device within the expandable tubular member; and
operating the expansion device to radially expand and plastically deform the remaining
portions of the expandable tubular member.
75. The method of claim 74, wherein the expansion device comprises an adjustable expansion device.
76. The method of claim 74, wherein the expansion device comprises a rotary expansion device.
77. The method of claim 74, wherein the expansion device comprises a pressurization device.
78. A system for radially expanding and plastically deforming an expandable tubular member, comprising:
means for positioning a resilient member within the interior of the expandable tubular
member;
means for compressing the resilient member within the interior of the expandable tubular
member to radially expand and plastically deform a portion of the expandable tubular
member;
means for positioning an expansion device within the expandable tubular member; and
means for operating the expansion device to radially expand and plastically deform the
remaining portions of the expandable tubular member.
79. The system of claim 78, wherein the expansion device comprises an adjustable expansion device.
80. The system of claim 78, wherein the expansion device comprises a rotary expansion device.

81. The system of claim 78, wherein the expansion device comprises a pressurization device.
82. A method of radially expanding and plastically deforming an expandable tubular member, comprising:
- positioning a resilient member within the interior of the expandable tubular member;
 - compressing the resilient member within the interior of the expandable tubular member to radially expand and plastically deform a portion of the expandable tubular member;
 - and
 - radially expanding and plastically deforming the expandable tubular member using an expansion device that does not comprise the resilient member.
83. The method of claim 82, wherein the expansion device comprises an adjustable expansion device.
84. The method of claim 82, wherein the expansion device comprises a rotary expansion device.
85. The method of claim 82, wherein the expansion device comprises a pressurization device.
86. A system for radially expanding and plastically deforming an expandable tubular member, comprising:
- means for positioning a resilient member within the interior of the expandable tubular member;
 - means for compressing the resilient member within the interior of the expandable tubular member to radially expand and plastically deform a portion of the expandable tubular member; and
 - means for radially expanding and plastically deforming the expandable tubular member that does not comprise the resilient member.
87. The system of claim 86, wherein the means for radially expanding and plastically deforming the expandable tubular member that does not comprise the resilient member comprises an adjustable expansion device.
88. The system of claim 86, wherein the means for radially expanding and plastically deforming the expandable tubular member that does not comprise the resilient member comprises a rotary expansion device.

89. The system of claim 86, wherein the means for radially expanding and plastically deforming the expandable tubular member that does not comprise the resilient member comprises a pressurization device.
90. An apparatus for radially expanding and plastically deforming an expandable tubular member, comprising:
- a support member;
 - a resilient member coupled to the support member;
 - an actuator operably coupled to the resilient member for controllably compressing the resilient member to thereby radially expand and plastically deform the expandable tubular member; and
 - an expansion device coupled to the support member that does not comprise the resilient member.
91. The apparatus of claim 90, wherein the expansion device comprises an adjustable expansion device.
92. The apparatus of claim 90, wherein the expansion device comprises a rotary expansion device.
93. The apparatus of claim 90, wherein the expansion device comprises a pressurization device.